



FX202E3 Combistar™ Electric Combi Oven

Combi oven constructed in stainless steel • Boilerless dual level steam generation system • AISI 316L marine grade stainless steel upper and bottom cavity • Cooking fan and steam generator in AISI 316L marine grade stainless steel • Stainless steel gas exchangers • Electric exchanger made of Incoloy 800 • Halogen cavity lighting • Tempered glass control panel • Programmable controls with touch display • 150 cooking programs with capability of up to 18 steps each • 76 program automatic cooking icon files • Favorites menu • USB interface • 6 speed auto-reverse fan with static function • ECO mode function • Removable AISI 316 stainless steel container rack for models 61, 101,82,122 • Removable AISI 304 stainless steel roll in rack for 201 and 202 models • Deflector panel on hinges between heat exchanger and cooking cavity • Ceramic fiber thermal insulation with anti-radiation barrier • Ergonomic handle with double handgrip • 7 automatic washing programs with triple-action sanitation • Simultaneous multi-cooking • Multi-timer (20 recipe capability) with 2 core probe capability • Steam, convection and combination cooking modes with automatic cooking for pasteurization, smoking, sous vide, holding, dehydration, steaming, browning, searing, cooking in Delta T and Low Temperature.

TEMPERATURE RANGE

Convection
50°F-572°F (10°C-300°C) // 0%-100% Humidity

Steam
86°F-257°F (30°C-125°C)

Combination
86°F-482°F (30°C-250°C) // 0%-90% Humidity

CAPACITY

- (20) 18" x 26" Sheet Pans
- (40) 12" x 20" x 2.5" Hotel Pans

CERTIFICATION



SPECIALTY COOKING PROGRAMS

- Holding
- Delta T
- Low Temperature Cooking
- Rethermalization
- HACCP Control Management
- Hot & Cold Smoking
- Pasteurization Cooking
- Dehydrating
- Advanced Cook & Chill Interface Technology

OPTIONAL ACCESSORIES

- FMSX Smoke
- Pasteurization Kit
- Heat Shield
- Stand (Open & Closed)
- Sous vide probe
- Frame w/casters (for stacked ovens)
- Casters, Set of 4 (2 with brakes)
- Video and HACCP



Model	FX202E3 Combistar™			
Description	Electric Combi Oven, 208V or 240V or 480V 60Hz 3Phase, Boilerless (20) 18" x 26" Sheet Pans or (40) 12" x 20" x 2.5" Hotel Pans			
Exterior Dimensions WxDxH	46-39/64" x 43-15/64" x 72-39/64" (1183 x 1098 x 1855 mm)			
Interior Dimensions WxDxH	35 3/64" x 32 31/64" x 57 31/64" (890 x 825 x 1460 mm)			
Crated Dimensions WxDxH	51-3/8"x47-1/4"x85-35/64" (1305 x 1200 x 2173 mm)			
Weight	Net Weight	1014 lb (460 kg)	Shipping Weight	1127 lb (511 kg)
Pan Capacity	Sheet Pan [18"x26"]	Twenty (20)	Hotel Pan [12"x20"x2.5"]	Forty (40)
Pan Module Distance	2-19/32" (66 mm)			
Product Capacity	426 Quarts (404 l) - 507 lb (230Kg) Max			

Electric Power	Voltage	Cycle/Hz	Phase	Kilowatt	Amps	AWG
	208V	60Hz	3Ph	52Kw	144.5A	AWG12
	240V	60Hz	3Ph	35.8Kw	86.2A	AWG12
	480V	60Hz	3Ph	35.8Kw	43.1A	AWG12

Notes: The electrical supply must be specified on order

WATER INLET	Inlet	3/4"	Line Pressure	30-60 psi (2 -4 bar)
Required	Chlorine	< 0.1 ppm (mg/l)	Chlorides	< 30 ppm (mg/l)
	Sulphates	< 30 ppm (mg/l)	Iron	< 0.1 ppm (mg/l)
	Copper	< 0.05ppm (mg/l)	Manganese	< 0.05ppm(mg/l)
Hardness	3 to 9° f (1.5 to 5 °d; 2.1 to 6.3 °e; 30 to 90 ppm)			
Langelier Index	> 0.5			
TDS	40 to 150 ppm			
Flow Rate :	4.6 Gallons/h			
PH	7 to 8.5			
WATER OUTLET	1-1/4" Drain with Air Gap			

INSTALLATION REQUIREMENTS	Hood Installation is required // The oven must be installed level // Water supply shut-off valve and back flow preventer must be installed (by others)
CLEARANCE REQUIREMENTS	Left Side: 20" from heat source and 19" recommended for service access // Minimum clearance 6-1/2" when left side clearance is less than 20" from a heat source, please inquire about a Angelo Po heat shield accessory.
	Right Side: Minimum clearance 3-57/64"
	Top: Minimum clearance 12"
	Bottom: Minimum clearance 4" (also in the counter top installations)
	Back: 20" from heat cooking equipment (oven in the middle of the room) - Minimum clearance 4"
Notes:	<ol style="list-style-type: none"> Water must meet minimum specified quality standards (see spec sheet) or appropriate filtration will be required. Pressure: WITH Angelo Po RO System = 50 - 125 psi; WITHOUT RO = 30-60 psi Drain cannot be directly under combi oven Chemicals - Please allow location for chemicals when ordering double stack ovens Electrical - No GFCI plugs on gas ovens. Local code may require a service disconnnet on electrical seal tight conduit (provided by a licensed electrician) RO System- Pre-determine wall mounting location when choosing optional RO system, maximum 15ft. from oven It is highly recommended that the Angelo Po reverse osmosis water treatment systems (APRO), as well as Angelo Po brand cleaning chemicals (CL55XL detergent and BR55XL brightener) be used and incorporated into all Angelo Po Combistar combi oven installations. It is the sole responsibility of the owner / operator / purchaser of the Angelo Po equipment, to verify that the incoming water supply is comprehensively tested to meet the Angelo Po water compliance standards, published in this document. Non-compliance with the Angelo Po water standards noted herein could potentially damage the equipment and/or VOID the original manufacturer's standard warranty. Call Angelo Po America customer care or technical service if there is any further clarification required.

Stacking Solutions	Not Stackable
Max Ext. Stacked Dimensions	n.a.

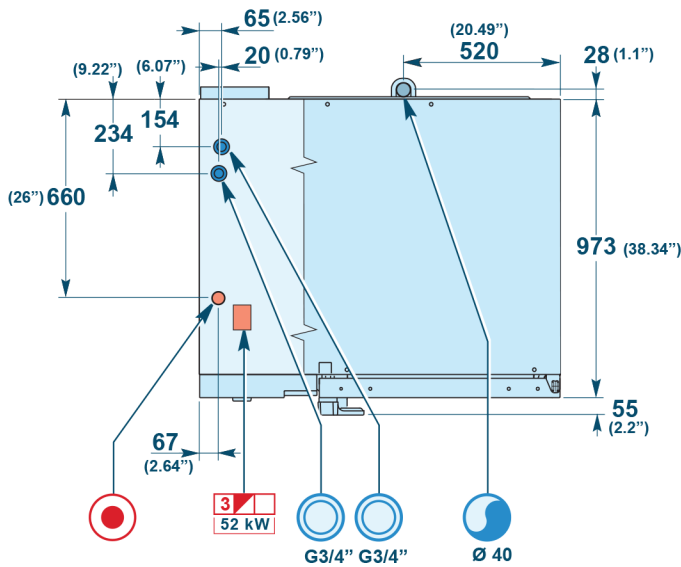
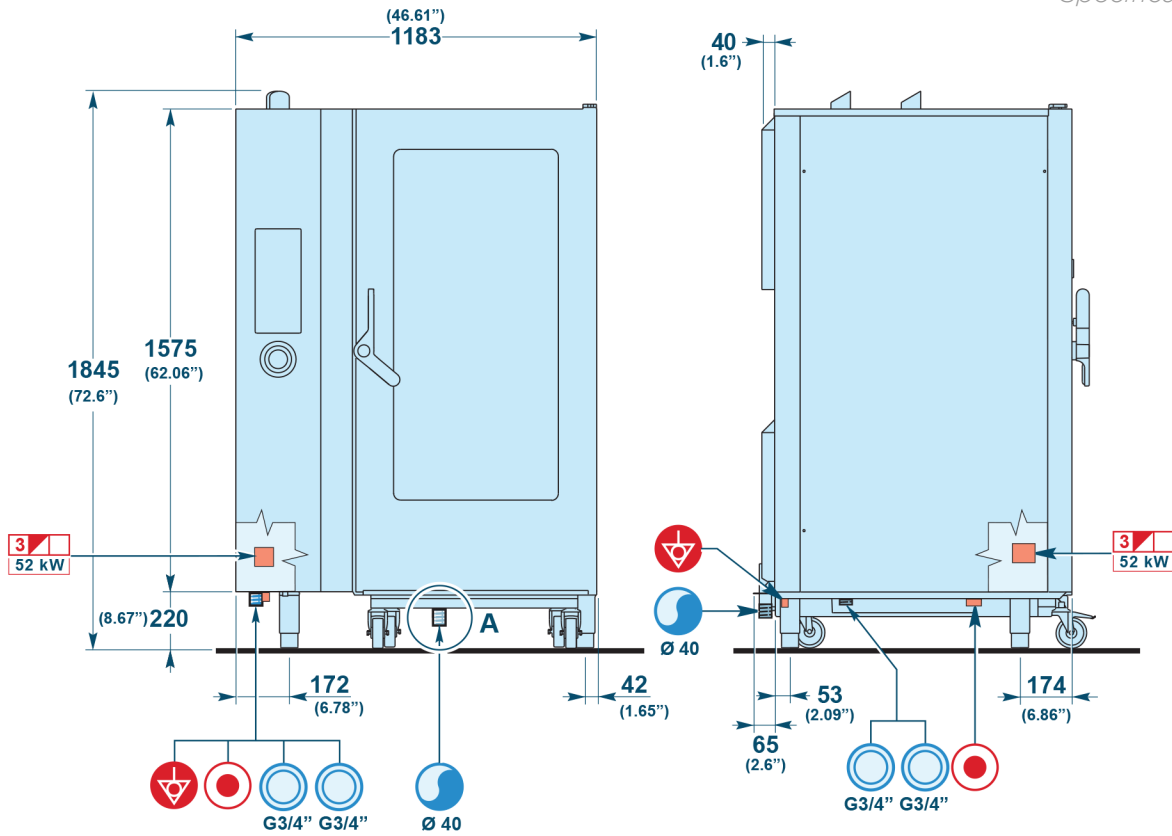

 Cold water input
Entrée eau froide

 Electric connection
Branchement électrique

 Terminal board
Plaque à bornes
3~
480 V

 Water drain
Vidage eau

 Equipotential terminal
Borne équipotentiel

Unit of measurement = mm / in
Unité de mesure = mm / in